

# OAK

GAS & ELECTRIC  
COLLECTION



# GEM

GAS, ELECTRIC & MULTIFUEL



## Why our flame is so natural...

Our range of balanced flue gas stoves gives a beautiful lazy dancing flame pattern which emulates that of a traditional wood burning stove and with the added features of being Clean, Odourless, Efficient & Easy to use.

## Our Technology & Engineering Excellence

From our modern manufacturing facility near the coast in West Glamorgan, South Wales we fully manufacture our range of modern contemporary stoves. Our collection has been designed with the latest gas burning efficient technology, which is inherently safe, delivers a beautiful flame pattern with glowing log embers within an attractive looking stove which will be the key feature in any room.

The stoves are fully controllable from 2kW up to 5.5kW allowing any room to warm quickly from cold. Once at the required temperature the stove is managed thermostatically to maintain the required room temperature. All of our stoves have a twin wall steel body system allowing the stove to produce radiant and convectional heat giving excellent heat distribution to any room. They also give you an excellent view of the flame from whatever your position in the room.

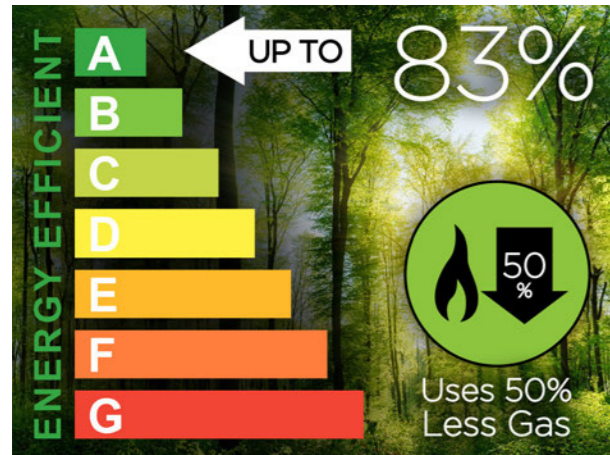

### Efficiency

All of our gas stoves have an extremely high efficiency, testing up to 83%. This means they are rated at an A Grade for efficiency as defined for a decorative balanced flue stove.

Our technology gives a superior depth and height of flame and our Eco-Flame feature allows the flame to alternate from the back to the front, giving a dancing depth of flame that uses up to 50% less gas.



### Safety & Reliability

Our gas stove collection has been fully tested and certified in the UK by one of the leading global independent gas testing bodies, which fully conforms to the British and European standards and is fully CE accredited.

As with any gas appliance safety is of paramount importance, which is why we have built many additional safety features into our stoves to ensure safe and reliable performance.



### Fully Remote Controlled

Our stoves are simple to use, you can just sit back and relax. The hand-held remote control allows you to control all of the features of the stove, you can pre-set the thermostatically controlled timer so the stove will come on and go off via the remote control as you would your central heating system.

You can also control the flame picture of the stove by the simple touch of a button, turning the flames from the highest setting to their lowest. Controllability at your fingertips and a fantastic flame picture give you all the advantages of a contemporary wood burning stove but none of the hard work.

The four elements of nature:

Fire, Water  
Earth & Air

*From the beginning of time we have always been attracted to a beautiful warming flame and glowing embers.*



Picture of a Serenita gas balanced flue stove dancing flame pattern



Also available in Electric Version

# DRIFTER GRAND

Our Drifter range is possibly our most eye-catching with its full frame windows giving you the maximum impact of the flame.

The Drifter's oval body shape also makes it a unique and stunning centrepiece.

- Fully remote controlled
- Dual burner technology for variable flame picture
- High efficiency up to 83%
- Eco-flame mode for reduced running costs
- Ceramic log fuel bed
- Double glazed door & side panels
- Extended glass door & side panels
- Convectional & Radiant heat output
- Only requires a 500mm high balanced flue exit

Front View  
DRIFTER-GW



Side View  
DRIFTER-GW



- Radiant & Convectional
- 500mm Top Exit
- Double Glazed
- Balanced Flue
- Remote Operation
- Dual Burner
- 2 Year Warranty
- 83% Efficiency
- 5.5 kW Heat Output
- Eco-Flame Mode
- 75 mm Distance To Combustibles

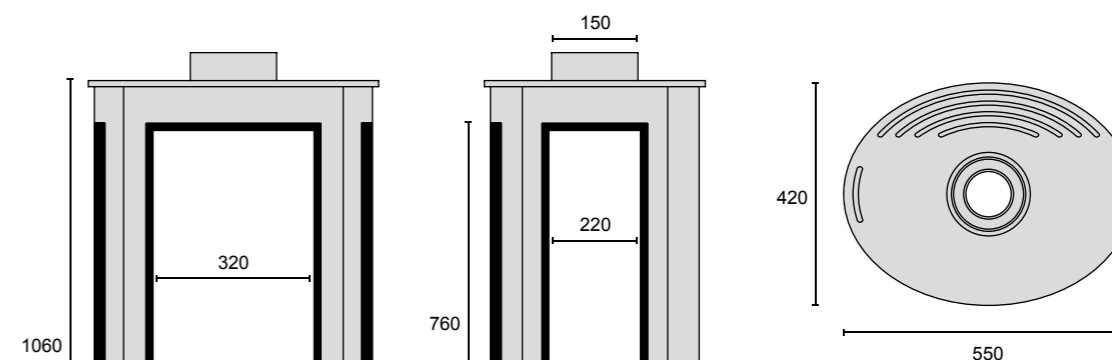

**Colour:** Matt Black  
*(Others available, call for details)*

**Flue Outlet:** Top exit (500mm min)

**Fuel Type:** Natural gas or LPG option  
*(See page 22 for details on our Electric Range)*

**Materials:** Steel body, ceramic glass & ceramic fuel bed.





# DRIFTER PEDESTAL

The Drifter Pedestal is an elegant alternative to the Grand model, with the finesse you get with pedestal stoves.

It still features the same large full frame windows and stands at the same height as the Grand.

- Fully remote controlled
- Dual burner technology for variable flame picture
- High efficiency up to 83%
- Eco-flame mode for reduced running costs
- Ceramic log fuel bed
- Double glazed door & side panels
- Extended glass door & side panels
- Convectional & Radiant heat output
- Only requires a 500mm high balanced flue exit

Front View  
DRIFTER-PW



Side View  
DRIFTER-PW



- Radiant & Convectional
- 500mm Top Exit
- Double Glazed
- Balanced Flue
- Remote Operation
- Dual Burner
- 2 Year Warranty
- 83% Efficiency
- 5.5 kW Heat Output
- Eco-Flame Mode
- 75 mm Distance To Combustibles

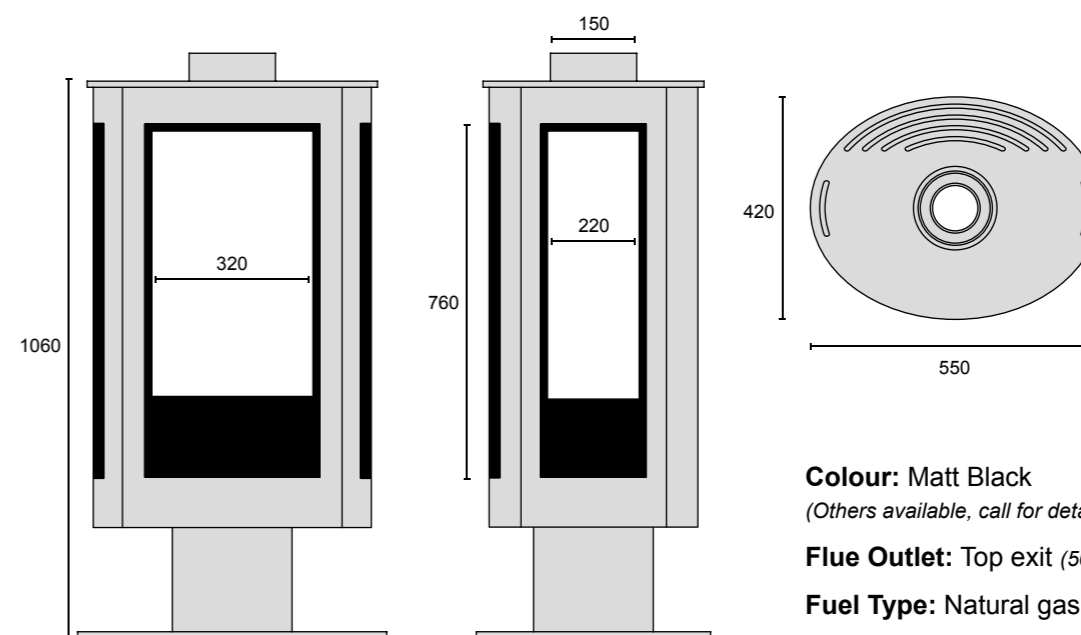

**Colour:** Matt Black  
(Others available, call for details)

**Flue Outlet:** Top exit (500mm min)

**Fuel Type:** Natural gas or LPG option

**Materials:** Steel body, ceramic glass & ceramic fuel bed.





# DRIFTER COMPACT

Our Drifter Compact again features the same stunning full frame windows and oval body shape. However it stands at a fraction of the height.

A unique shaped stove that is still perfect for fireplaces or inglenook's.

- Fully remote controlled
- Dual burner technology for variable flame picture
- High efficiency up to 83%
- Eco-flame mode for reduced running costs
- Ceramic log fuel bed
- Double glazed door & side panels
- Extended glass door & side panels
- Convectional & Radiant heat output
- Only requires a 500mm high balanced flue exit

Front View  
DRIFTER-CW



Side View  
DRIFTER-CW



- Radiant & Convectional
- 500mm Top Exit
- Double Glazed
- Balanced Flue
- Remote Operation
- Dual Burner
- 2 Year Warranty
- 83% Efficiency
- 5.5 kW Heat Output
- Eco-Flame Mode
- 75 mm Distance To Combustibles

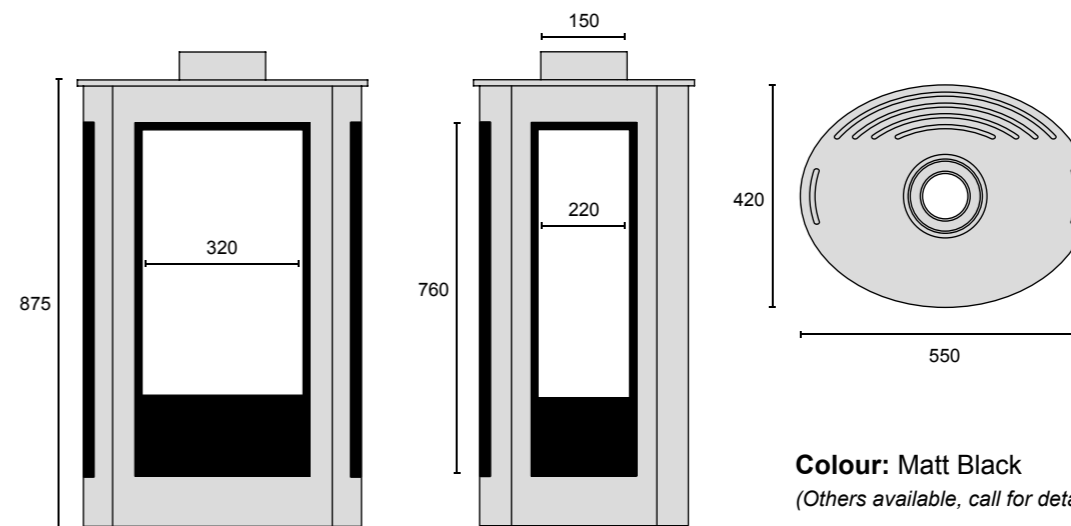

**Colour:** Matt Black  
*(Others available, call for details)*

**Flue Outlet:** Top exit (500mm min)

**Fuel Type:** Natural gas or LPG option

**Materials:** Steel body, ceramic glass & ceramic fuel bed.





Also available in Electric Version

# SERENITA GRAND

The Serenita is a range of fully round bodied gas stoves available in Grand, Pedestal and Compact options. Their dancing flame pattern will enhance and warm any room.

The Serenita Grand is a contemporary style stove with a unique personality. Its bold lines make it stand out as a stunning centrepiece.









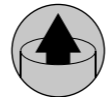

- Fully remote controlled
- Dual burner technology for variable flame picture
- High efficiency up to 83%
- Eco-flame mode for reduced running costs
- Ceramic log fuel bed
- Double glazed door & side panels
- Panoramic curved glass door & side panels
- Convectional & Radiant heat output
- Only requires a 500mm high balanced flue exit

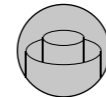
Front View  
SERENITA-GW



Side View  
SERENITA-GW

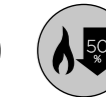

-  Radiant & Convectional
-  500mm Top Exit
-  Double Glazed
-  Balanced Flue
-  Remote Operation
-  Dual Burner
-  2 Year Warranty
-  83% Efficiency
-  5.5 kW Heat Output
-  Eco-Flame Mode
-  75 mm Distance To Combustibles

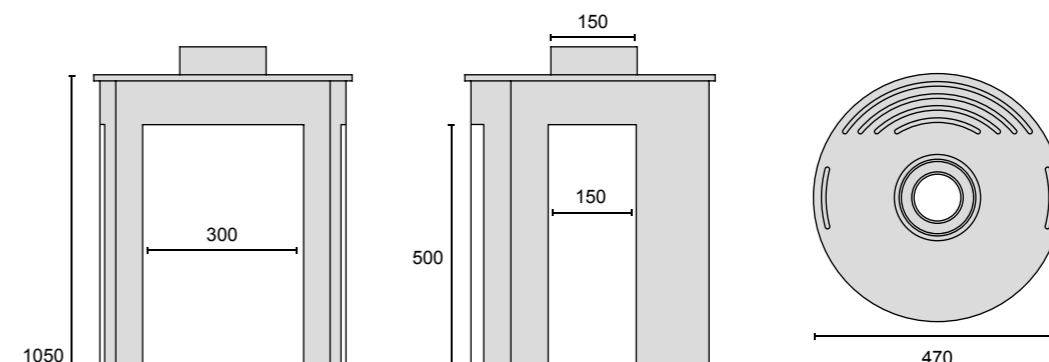

**Colour:** Matt Black  
*(Others available, call for details)*

**Flue Outlet:** Top exit (500mm min)

**Fuel Type:** Natural gas or LPG option  
*(See page 22 for details on our Electric Range)*

**Materials:** Steel body, ceramic glass & ceramic fuel bed.





Also available in Electric Version

# SERENITA PEDESTAL

The Serenita Pedestal is sleek and elegant with its large curved panoramic glass panel and one piece door. This allows the flame picture to be viewed from most angles in the room.

This free standing stove with its single round pillar offers an ultra modern feel to your home and becomes an attractive centrepiece in any room.

- Fully remote controlled
- Dual burner technology for variable flame picture
- High efficiency up to 83%
- Eco-flame mode for reduced running costs
- Ceramic log fuel bed
- Double glazed door & side panels
- Panoramic curved glass door & side panels
- Convectional & Radiant heat output
- Only requires a 500mm high balanced flue exit

Front View  
SERENITA-PW



Side View  
SERENITA-PW



- Radiant & Convectional
- 500mm Top Exit
- Double Glazed
- Balanced Flue
- Remote Operation
- Dual Burner
- 2 Year Warranty
- 83% Efficiency
- 5.5 kW Heat Output
- Eco-Flame Mode
- 75 mm Distance To Combustibles

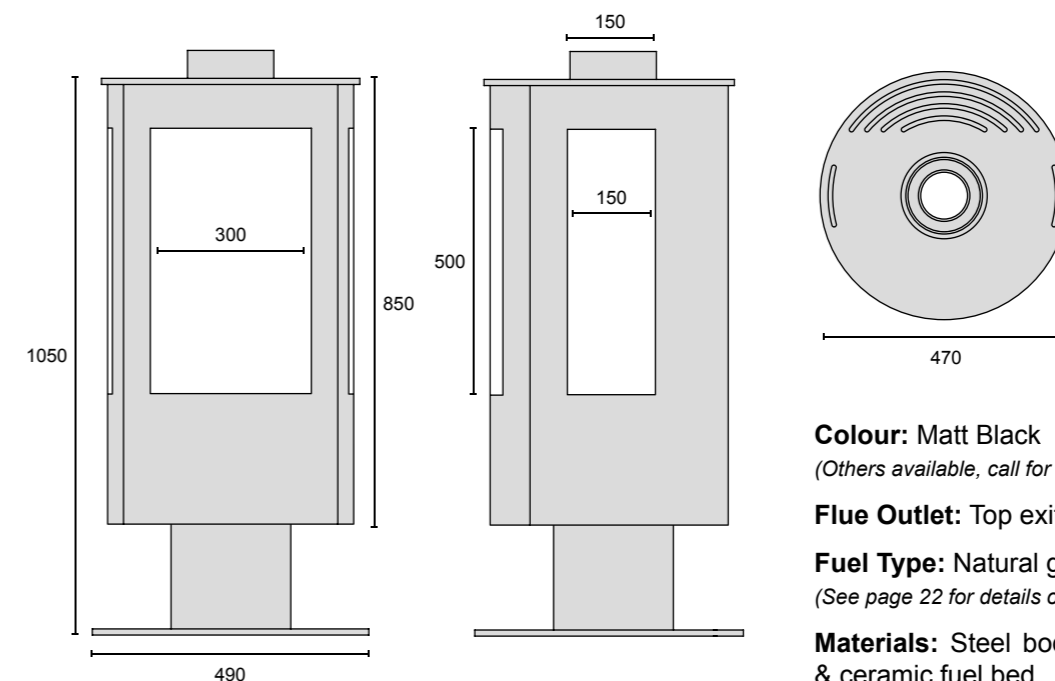

**Colour:** Matt Black  
(Others available, call for details)

**Flue Outlet:** Top exit (500mm min)

**Fuel Type:** Natural gas or LPG option  
(See page 22 for details on our Electric Range)

**Materials:** Steel body, ceramic glass & ceramic fuel bed.





⚡ Also available in Electric Version

# SERENITA COMPACT

The Serenita Compact is modern and sophisticated. It has been specifically designed to be shorter in its overall height, yet it has exactly the same unique features as the Grand and Pedestal.

The Compact will fit into most fireplaces, however it looks fantastic and graceful either in an inglenook or free standing in a room with its modern sleek styling.

- Fully remote controlled
- Dual burner technology for variable flame picture
- High efficiency up to 83%
- Eco-flame mode for reduced running costs
- Ceramic log fuel bed
- Double glazed door & side panels
- Panoramic curved glass door & side panels
- Convectional & Radiant heat output
- Only requires a 500mm high balanced flue exit

Front View  
SERENITA-CW



Side View  
SERENITA-CW



- Radiant & Convectional
- 500mm Top Exit
- Double Glazed
- Balanced Flue
- Remote Operation
- Dual Burner
- 2 Year Warranty
- 83% Efficiency
- 5.5 kW Heat Output
- Eco-Flame Mode
- 75 mm Distance To Combustibles

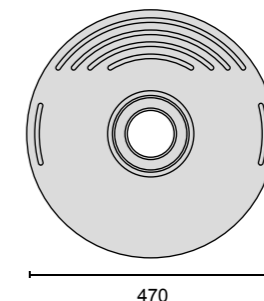
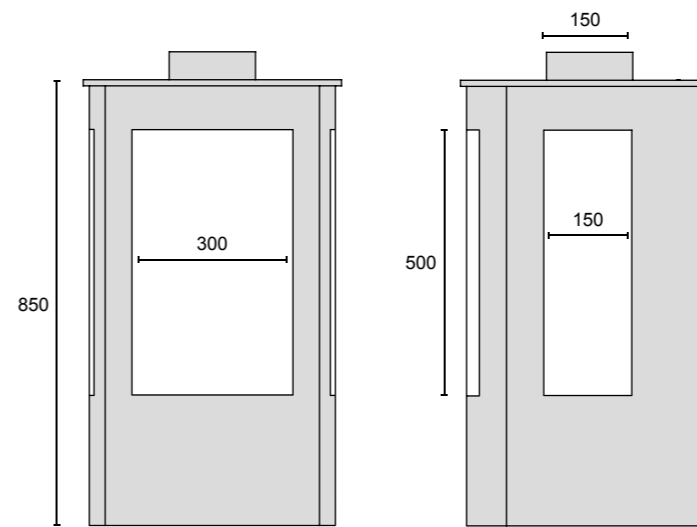

**Colour:** Matt Black  
*(Others available, call for details)*

**Flue Outlet:** Top exit (500mm min)

**Fuel Type:** Natural gas or LPG option  
*(See page 22 for details on our Electric Range)*

**Materials:** Steel body, ceramic glass & ceramic fuel bed.







⚡ Also available in Electric Version

# SPA GRAND

Our Spa range has all of the same features and options as the Drifter & Serenita models, but with a slimmer design and flat sides. This minimalised profile offers a different styling design.

However, it still has the curved panoramic glass and the large side windows so you really see the depth of the dancing flame.









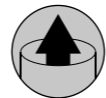

- Fully remote controlled
- Dual burner technology for variable flame picture
- High efficiency up to 83%
- Eco-flame mode for reduced running costs
- Ceramic log fuel bed
- Double glazed door & side panels
- Panoramic curved glass door & flat side panels
- Convectional & Radiant heat output
- Only requires a 500mm high balanced flue exit

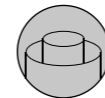
Front View  
SPA-GW



Side View  
SPA-GW



-  Radiant & Convectional
-  500mm Top Exit
-  Double Glazed
-  Balanced Flue
-  Remote Operation
-  Dual Burner
-  2 Year Warranty
-  83% Efficiency
-  5.5 kW Heat Output
-  Eco-Flame Mode
-  75 mm Distance To Combustibles

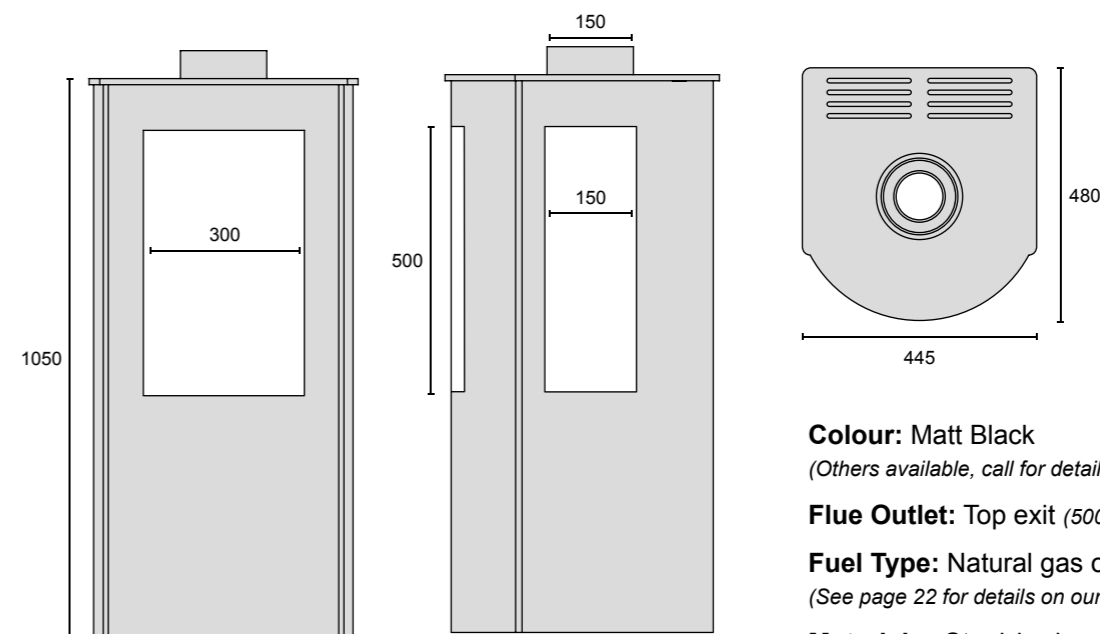

**Colour:** Matt Black  
*(Others available, call for details)*

**Flue Outlet:** Top exit (500mm min)

**Fuel Type:** Natural gas or LPG option  
*(See page 22 for details on our Electric Range)*

**Materials:** Steel body, ceramic glass & ceramic fuel bed.





Also available in Electric Version

# SPA COMPACT

The Spa Compact has the same features as the Grand model and is shorter in its overall height. It has the same beautiful curved door and panoramic glass as the Serenita, however the rest of the body is square.

This modern shape is ideal for traditional fireplaces as its sides fit snugly against the rear and side of a fireplace opening.

- Fully remote controlled
- Dual burner technology for variable flame picture
- High efficiency up to 83%
- Eco-flame mode for reduced running costs
- Ceramic log fuel bed
- Double glazed door & side panels
- Panoramic curved glass door & flat side panels
- Convectional & Radiant heat output
- Only requires a 500mm high balanced flue exit

Standard SPA-C



Side Window SPA-CW



- Radiant & Convectional
- 500mm Top Exit
- Double Glazed
- Balanced Flue
- Remote Operation
- Dual Burner
- 2 Year Warranty
- 83% Efficiency
- 5.5 kW Heat Output
- Eco-Flame Mode
- 75 mm Distance To Combustibles

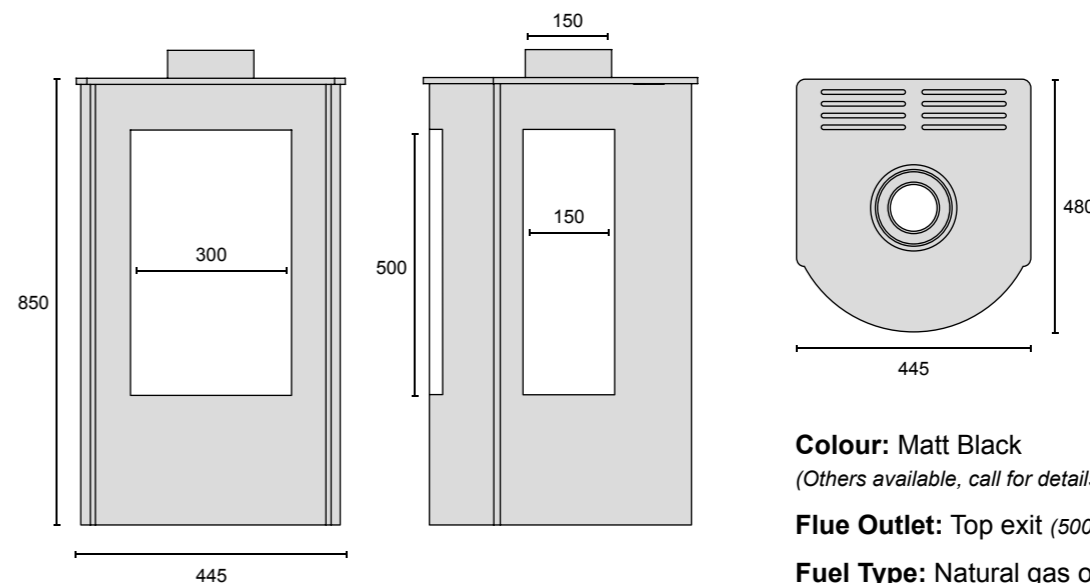

**Colour:** Matt Black  
*(Others available, call for details)*

**Flue Outlet:** Top exit (500mm min)

**Fuel Type:** Natural gas or LPG option  
*(See page 22 for details on our Electric Range)*

**Materials:** Steel body, ceramic glass & ceramic fuel bed.



# OUR TECHNOLOGY

## Efficiency

	Natural Gas		LPG Gas	
	High Flame	Low Flame	High Flame	Low Flame
Gross (Net) Gas Input kW	8.0 (6.9)	2.2	7 (6)	2
Net Efficiency	81%	-	83%	-
Net Heat Output	5.5kW	-	5kW	-

Please Note: These stoves have either a Natural or LPG Gas burner fitted depending on your specification. Both types of fuel can not be burned by the same stove.

## Distance To Combustibles

	Minimum clearance from combustible materials		Minimum clearance from non-combustible materials	
	Without Side Windows	With Side Windows	Without Side Windows	With Side Windows
Rear	75	75	50	50
Side	300	500	50	50
Top	300	300	50	50
Front	75	75	75	75

When fitting a gas stove appliance the installation must comply with Gas Safe and building regulations.

## Feature Guide

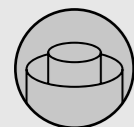

### Balanced Flue

A twin walled flue, the inner tube expels emissions and the outer tube draws in clean air - See our flue kits opposite.



### 2 Year Warranty

All our gas stoves come with a 2 year manufacturers warranty, giving you peace of mind with your purchase. (Exclusions apply)



### Dual Burner

Our dual burner gives our stoves that beautiful dancing flame, giving an authentic fire feel.



### Remote Operation

A hand held remote allowing full control of all the stoves features.



### 500mm Top Exit

These stoves have a balanced flue top exit suitable for a flue pipe with a minimum height of only 500mm to an elbow external exit from the room.

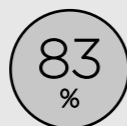

### 83% Efficiency

Our stoves have been tested and achieved a super-high efficiency score making our stoves A Rated.



### 5.5kW Heat Output

A huge heat output, comparable to a wood burning stove but at a fraction of the running costs and emissions.



### Eco-Flame Mode

This alternates between both burners, reducing gas usage by up to 50% but still keeping the full flame effect.



### Rear Distance To Combustibles

Our stoves have a rear distance to combustibles of just 75mm, giving you more freedom of placement.



### Double Glazed

All our gas stoves feature double glazed ceramic glass panels that give you a beautiful panoramic view of the fire.



### Radiant & Convectional

All our gas stoves are designed to produce radiant and convectional heat, allowing a better heat distribution into the room.

## Heat Distribution Output

Our stoves have a unique feature of radiant and convectional heat output. The diagram below illustrates how the stove draws in cool air from the room into the bottom of the stove and gently heats it up, outputting it as convectional heat from the top and sides.

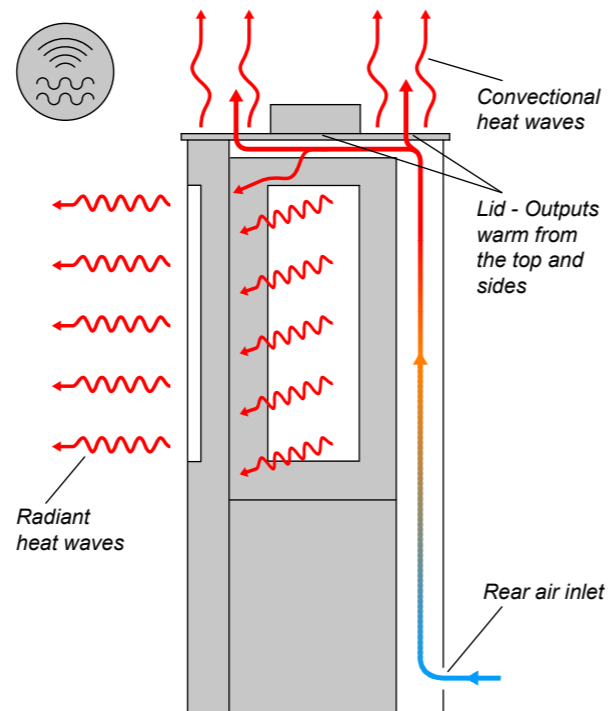

# CONNECTION

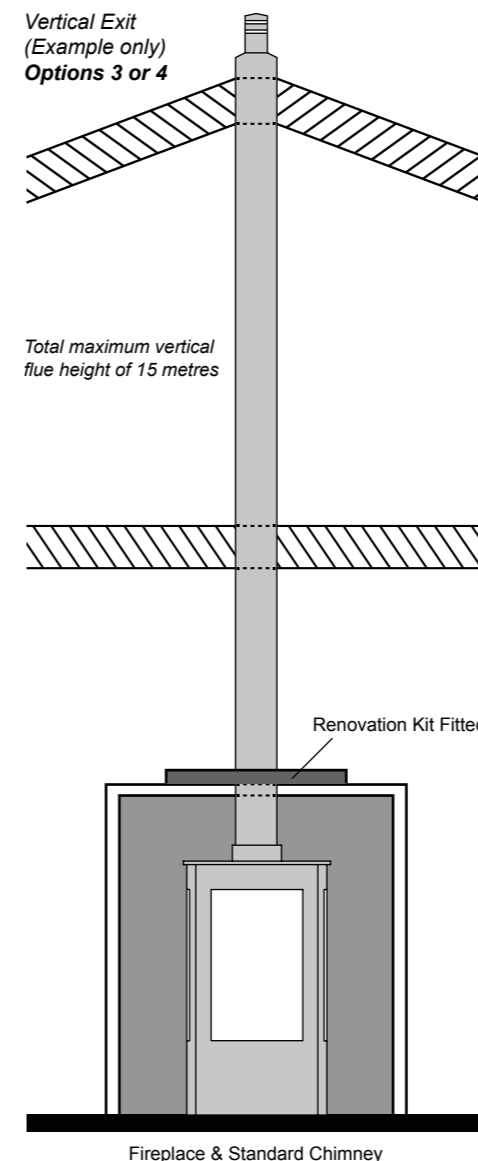
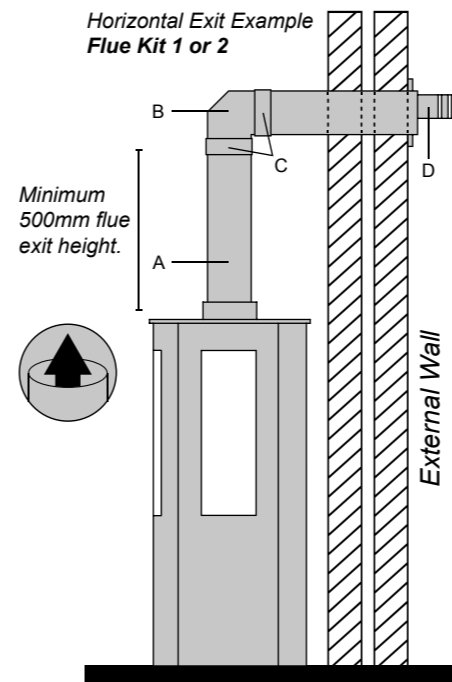

## Gas Balanced Flue System

Our stoves use a modular stainless steel concentric balanced flue system, comprising of an inner and outer flue tube. Natural convection draws the clean air from outside into the stove via the outer tube, while the inner tube expels the combustion gases out.

Our standard flue kits come in two different options for horizontal exits through walls, 500mm length or 1000mm length. All our flue kits are painted black to match the stoves.

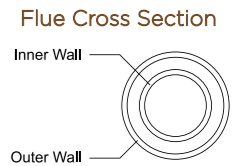

### Fitting using our concentric flue:

#### 1. Balanced Flue Kit 1

Qty	Ref	Description
1	A / 500	500mm Vertical Length
1	B	90 Degree Elbow
2	C	Smooth Locking Bands
1	D	100/150 Horizontal Terminal (Rain Cap End)

#### 2. Balanced Flue Kit 2

Qty	Ref	Description
1	A / 1000	1000mm Vertical Length
1	B	90 Degree Elbow
2	C	Smooth Locking Bands
1	D	100/150 Horizontal Terminal (Rain Cap End)

All flue components are powder coated black to match the stove.

3. As well as exiting through an external wall via a 90 degree elbow joint using Flue Kit 1 or 2, you can also exit vertically through the ceiling and roof (up to 15 metres) using our concentric balanced flue system. The fittings for this are not included in our standard kits, please contact your retailer for further details.

### Fitting into an existing chimney:

4. Alternatively if you're not fitting your stove using one of our concentric flue systems (options 1 to 3), you can also install your stove into an existing fireplace with a suitable chimney. Therefore any of our gas stoves can be fitted into an existing fireplace opening using a conventional flue system, but a "Renovation Kit" must be used. Please contact your retailer for further details.

Specifications	
Diameter Range (mm):	Inner - 100mm, Outer - 130mm
Inner Liner Material:	0.4mm Grade 304L Stainless Steel
Outer Liner Material:	0.4mm Grade 304L Stainless Steel
Joint Method:	Push fit and locking band
CE Approved:	Yes
Minimum Vertical Flue Height:	0.5m
Maximum Vertical Flue Height:	15m

We also offer a range of other painted flue parts so if Kit 1 or Kit 2 does not fully meet your installation needs please call us for more details.

ALSO AVAILABLE...



DRIFTER



SERENITA GRAND



SERENITA  
COMPACT & PEDESTAL



SPA GRAND

# ELECTRIC RANGE

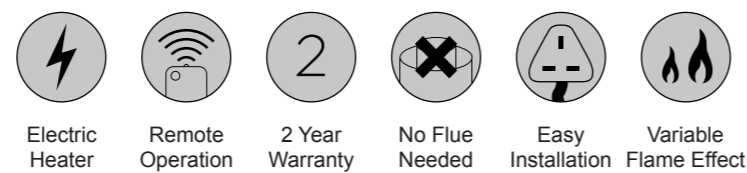

Our range of electric stoves are a stunning centre piece in any room, with a superb natural flame pattern and the added benefit of the freedom to place anywhere in your home as there is no need for a flue or chimney.

Available in Drifter, Serenita or Spa body configurations.

- Fully remote controlled
- Variable heat settings (High, Low or Flame Effect only)
- 100% efficiency
- No need for a flue
- Low distance to combustibles
- Easy installation - Just plug into a wall socket

**GEM**  
GAS, ELECTRIC & MULTIFUEL  
COLLECTION

BY **OAK**

### Efficiencies

	High Heat	Low Heat	Flame Effect Only
Power Input (Amp)	8.5A	4.5A	0.5A
Net Efficiency	100%	100%	-
Net Heat Output	2.0kW	1.0kW	-

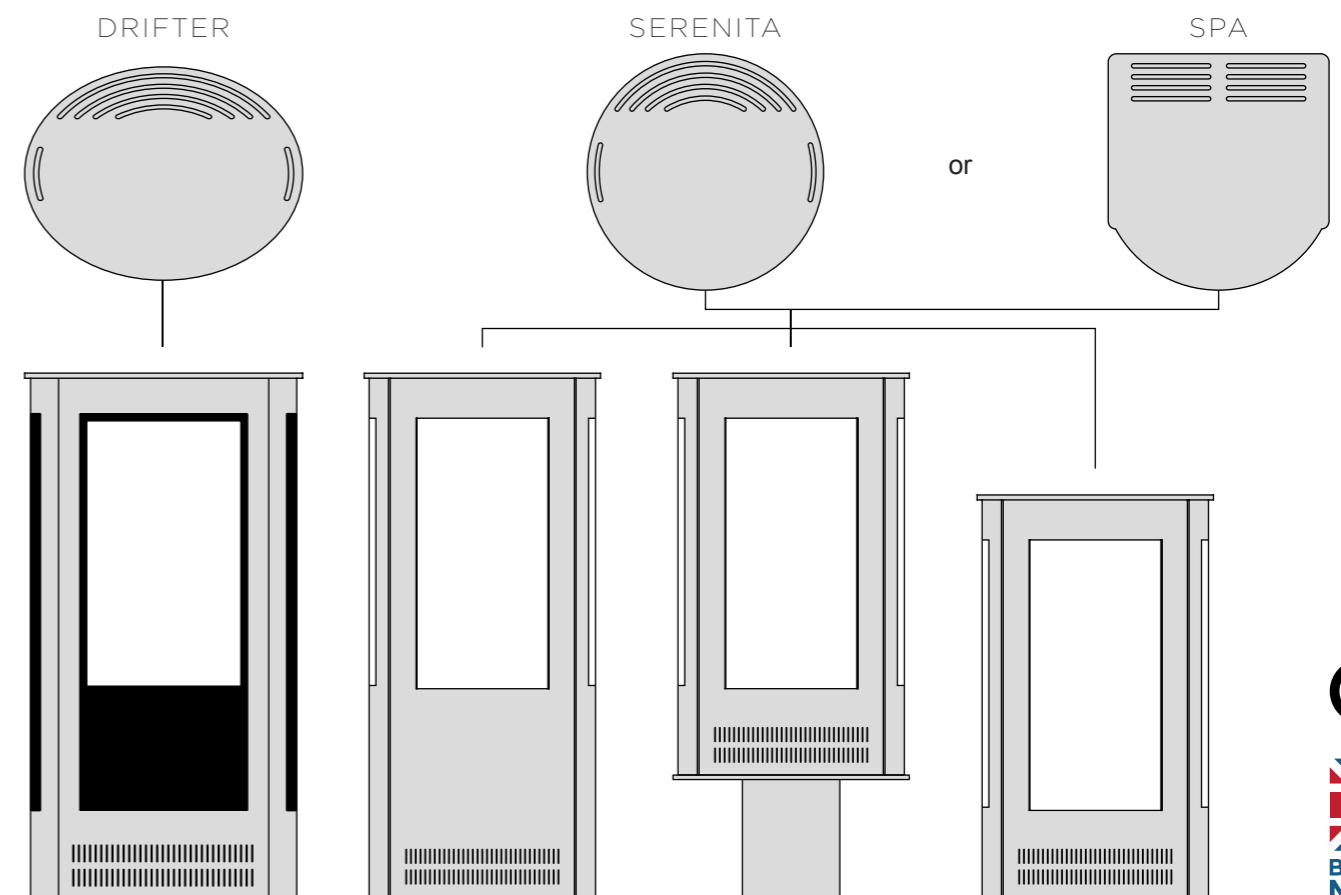

# OAK

GAS STOVES

## Key features of the Oak Stove Gas Collection

- Balanced flue gas technology
- Panoramic Double Glazed ceramic glass
- Large Double Glazed side window option
- Natural gas or LPG option
- Highly efficient and low running costs
- Mertik Maxitrol Symax gas valve control system
- Gas Control management system is powered by batteries as standard or a mains electricity option
- Variable Heat outputs from 2kW to 5.5kW
- Dual Burner technology for variable flame picture
- Eco-flame setting for reduced running costs
- Fully remote controlled for all features
- Thermostatically controlled
- Timer settings from the remote control
- Twin steel body system which produces radiant and conventional heat output
- Ceramic log fuel bed
- 75mm rear distance to combustibles
- Fully conforms to the British and European standards and fully CE accredited
- Inherently safe technology complete with a second flame supervision device for added safety across the dual burner unit
- 2 year manufacturers warranty
- Fully manufactured in the United Kingdom

Copyright © Oak Stoves 2017

Your local dealer is:

CE

